

ELRO®

DYSTRYBUTOR
Valmark Sp. z o.o.
tel: (22) 868 58 58
mail: biuro@valmark.pl

brands you trust.

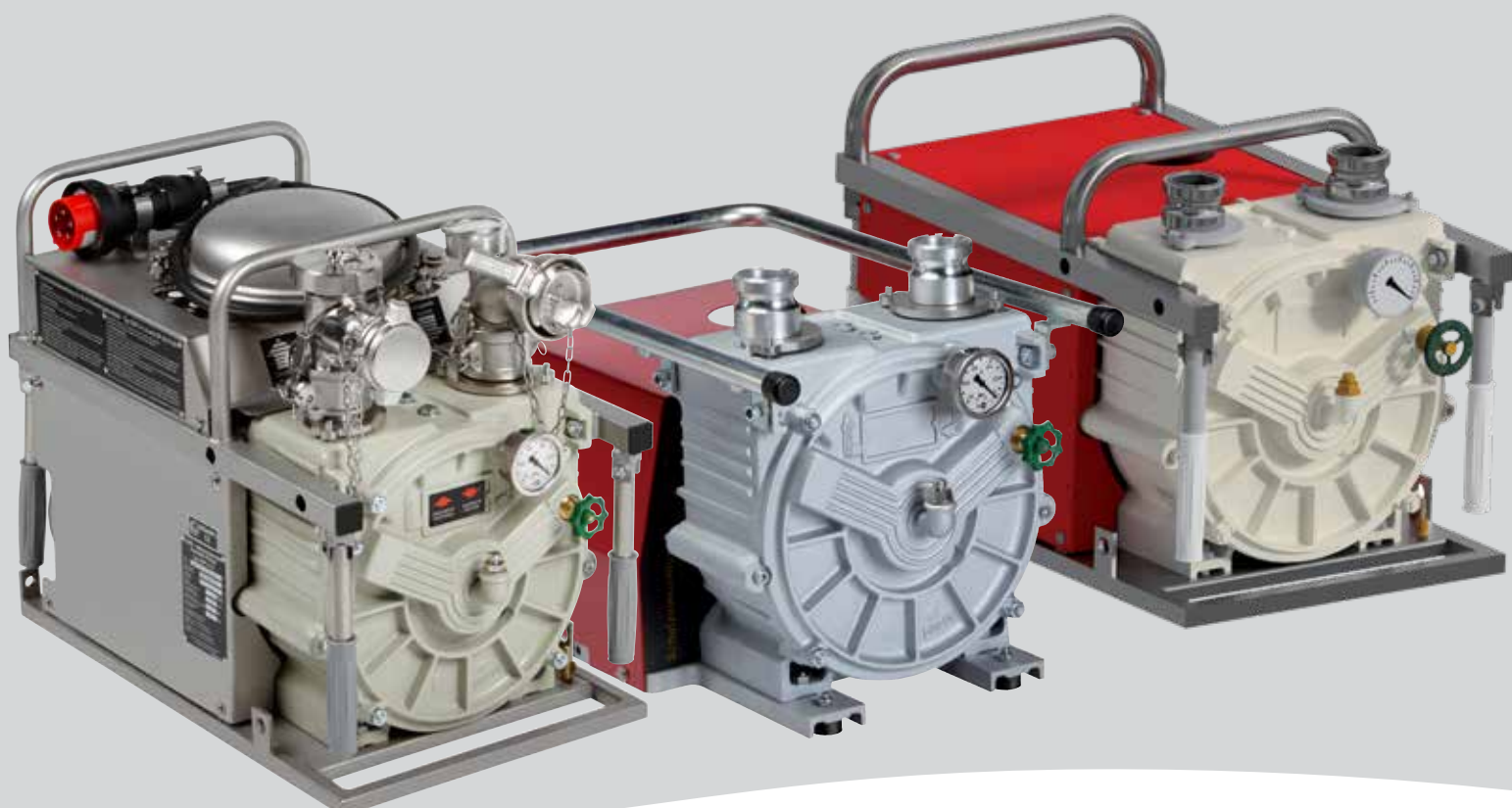

Technical Datasheet
ELRO® Series M

CRANE

Crane ChemPharma & Energy

www.elpumps.com
www.cranecpe.com

Features and Benefits

ELRO® Type M300, GUP 3-1,5 and GP 20/10 Ex peristaltic pumps are characterized by high mobility and outstanding displacement. They have an integrated vacuum system for constant flow rate and various portable base frames. A wide range of accessories enables optimal and efficient use in almost every application.

Key Features

- 1 Mobile unit with flow rates up to 20 m³/h effectively handles a wide range of applications, including contaminated and viscous media
- 2 The pump is able to self prime up to 9.5mWs without any additional accessories
- 3 The pump has only one wetted part (the hose) and delivers reliable service with a lower total cost of ownership



Drive

Type	E-Motor (Electric)	B-Motor (Petrol)	D-Motor (Diesel)	H-Motor (Hydraulik)	P-Motor (Pneumatic)	W-Motor (Water)
M300	●	●	●	●	●	●
GUP 3-1,5	●	-	-	-	-	-
GP 20/10 Ex	●	-	-	-	-	-

Type	M300	GUP 3-1,5	GP 20/10 Ex
Dry suction height (mWs)	max. 9.5		
Max. Solid Size [mm]	≤12		
Weight (kg)	52 - 76	98.4	90.4

Applications

- Chemical industry
- Fire brigades, rescue services
- Petroleum industry
- Color and paint industry
- Power stations
- Ports and ships
- Petrol stations and tank vehicles
- Airports

Features and Benefits

Temperature

Temperature Range: -20°C to +80°C

Product wetted interior	Max. Temperature (°C)
NR	-20 to +80
NBR	-10 to +80
CSM	-20 to +80

Marking and Identification

The pumps are provided with a nameplate containing the pump code, serial number, date of manufacture, and maximum allowed temperature and pressure.

The ELRO pump code provides all relevant information about the pump, performance, materials and accessories. This allows for accurate link to spare parts.

Applied Guidelines

EC directives:

- Machinery Directive 2006/42/EC
- Low voltage directive 2014/35/EU
- EMC directive 2014/30/EU
- Outdoor directive 2000/14/EC
- RoHS Directive 2011/65/EU
- ATEX Directive 2014/34/EU
- Eurasian Conformity

Harmonized standards:

- EN ISO 12100, EN ISO 13857, EN 809
- Firefighting equipment DIN14427



Elastomers



Natural rubber (NR)

Composition: natural substance, high-polymer isoprenes
 Properties: tension-resistant, elastic, cold-resistant, approved for food applications
 Operative range: for abrasive media, diluted acids and alkalis
 Temperature range: -20°C to +80°C / -4°F to +176°F



Nitrile rubber (NBR)

Composition: mixed polymeride from butadiene and acryl nitrile
 Properties: wear-resistant, grease and oil resistant
 Operative range: for oily and greasy media, alcohols
 Temperature range: -10°C to +80°C / +14°F to +176°F



Hypalon (CSM)

Composition: elastomer formed through polymerisation of chlorosulfonated ethyls
 Properties : chemical resistant, wear resistant and electric conductive (only M300)
 Operative range: for acids and alkalis, colours
 Temperature range: -20°C to +80°C / -4°F to +176°F

M300

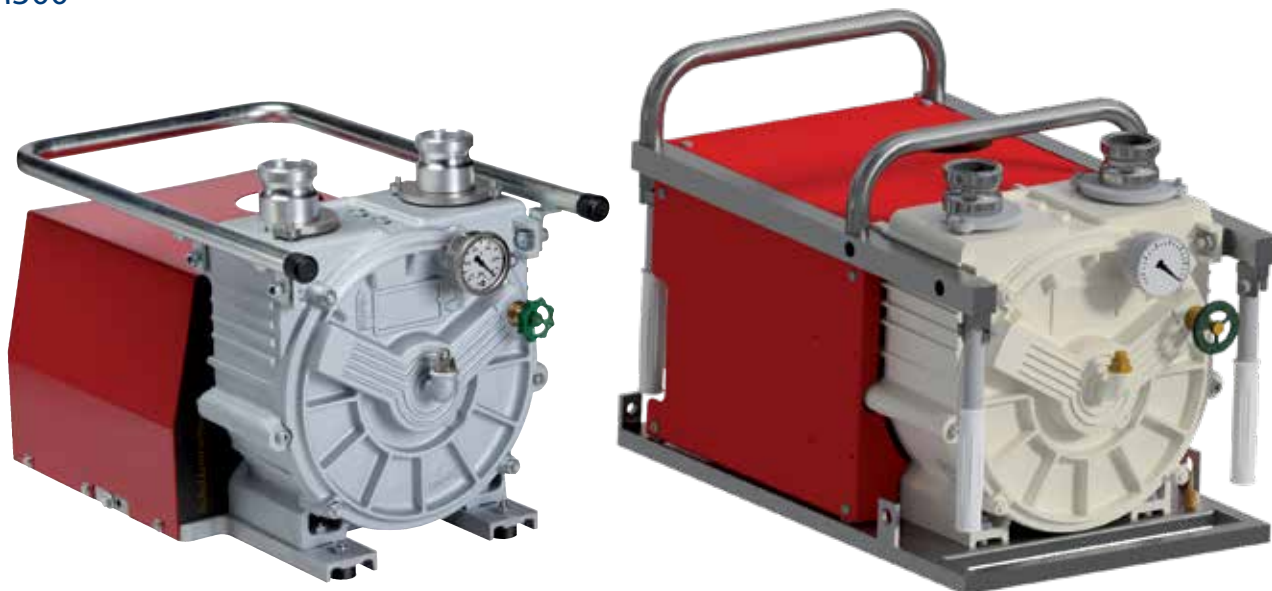

Materials & Characteristics

	M300							
	M20E	M20E Ex	M21E	M20B	M20 D	M20H	M20P	M20W
Drive Type	Electric Motor (Standard)	Electric Motor (ATEX)	Electric Motor (change-pole motor)	Gasoline engine	Diesel engine	Hydraulic engine	Pneumatic engine	Water turbine
Drive	3.6 kW/ 2920 rpm	3.3 kW/ 2920 rpm	3.1 / 2.6 kW/ 2800 / 1400 rpm	3.4 kW/ 3600 rpm	3.5 kW/ 3600rpm	3 kW/ 3000rpm	3 kW/ 2000rpm	3.5 kW/ 3600rpm
Power supply	three-phase current 400V / 50Hz			Octane no. ≥86	Cetane no. ≥45	13 MPa (130 bar)	0.6 MPa (6 bar)	0.85 MPa (8.5 bar)
Flow rate max.	18 m ³ /h (300 l/min)		9 / 18 m ³ /h (150 / 300 l/min)	20 m ³ /h (333 l/min)				
Pumping pressure max.	0.15 MPa (1.5 bar)			0.2 MPa (2 bar)				
Hose material	CSM, NBR, NR							
Connection material	Aluminium *), Stainless Steel 1.4571, Electrically-conductive Polypropylene, Brass							
On-Off Switch with motor protection	X			-				
Frame	Carrying frame	Fire brigade carrying frame	Carrying frame		Carrying frame with handles	Fire brigade carrying frame		
Protection class	IP54			-				
Power connection	5-pole male plug with 1.3 m connecting cable			-				
ATEX classification	-	II 2G Ex h IIB T3 Gb	-	-	-	II 2G Ex h IIB T3 Gb		

*) not for M20E Ex, M20H, M20P and M20W

GUP/GP

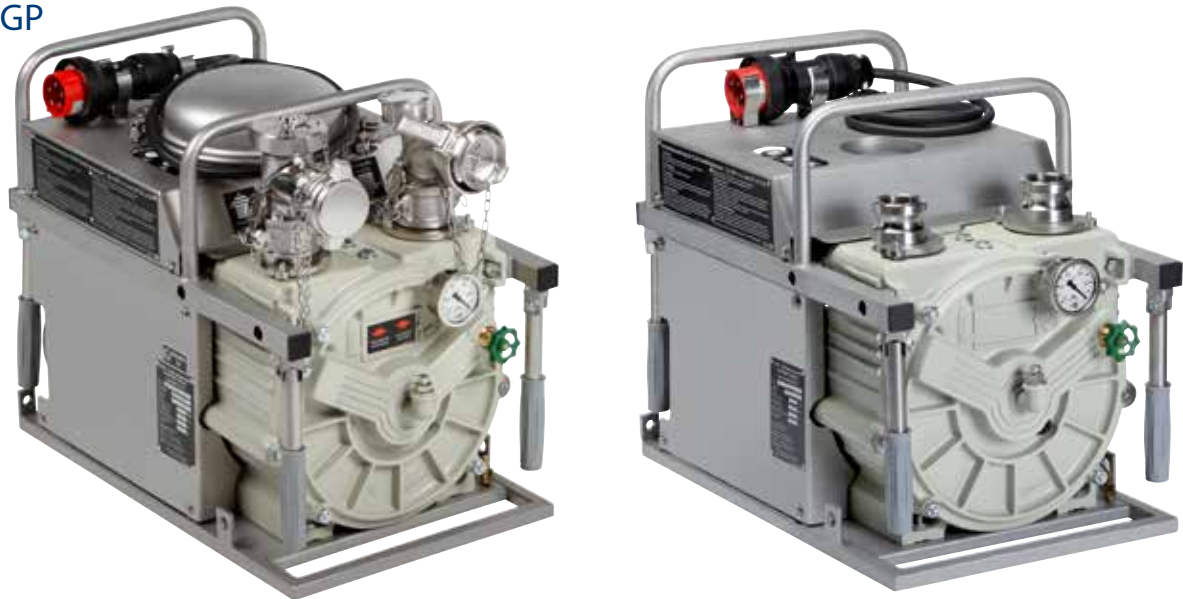

Materials & Characteristics

	GUP/GP	
	GUP 3-1,5	GP 20/10 Ex
Drive Type	Electric Motor (change-pole motor)	
Drive	2.1 / 2.75kW 1407 / 2857rpm	
Power supply	three-phase current 400V	
Flow rate max.	9 / 18m ³ /h (150 / 300 l/min)	
Pumping pressure max.	0.15 MPa (1.5 bar)	
Hose material	CSM	CSM, NBR
Connection material	Stainless Steel 1.4571	
ON-Off Switch with motor protection	x	
Frame	Fire brigade carrying frame	
Protection class	IP55	
Power connection	5-pole male plug with 1.3 m connecting cable	
Norm	Firefighting equipment DIN 14427	
ATEX-Conformity	II 2G Ex h IIB T3 Gb	
Fluid Connections	Inclusive tapered and threaded coupling or tank lorry coupling	Camlock-male. Optional couplings
Accessories	Pulsation damper & light socket included	Pulsation damper & light socket optional

Series M - Operation

Innovative Technology with Tradition

Since 1993 the ELRO pumps for hazardous materials in form of mobile units have established themselves as indispensable products for fire brigades, relief organisations, factory security staff and military.

Day in and day out these pumps demonstrate their reliability and efficiency under the most demanding operational conditions.

The quality demands of customers as well as ease of operation and maintenance are uppermost in the manufacture of these new products.

Traditional values in combination with long experience and the available pump / application know-how enables market specific solutions in agreed timescales.

Benefits at a Glance:

- ideal for abrasive, viscous media and media harmful to the environment.
- gentle pumping of liquid and viscous hazardous substances
- constant volume capacity due to vacuum support
- dry running resistant
- pumping of media with entrained solids
- unobstructed fluid flow & easy cleaning
- free of dynamic and pressurised seals
- mobile, easy to transport design
- two-stage adjustment of the pumping capacity possible
- no additional vacuum equipment required
- dry self-priming max. 9.5 m lift

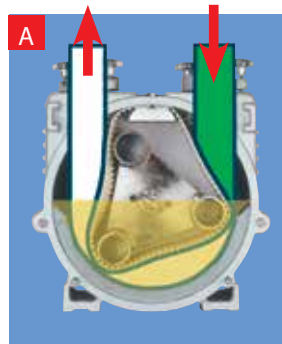

The rotor turns inside the tightly fixed separator, which is held in the pump housing filled with lubricant. The separator divides the housing into two completely enclosed areas. This means during compression of the pumping hose the suction and discharge sides are hermetically separated.

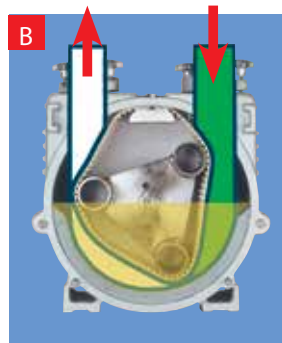

Air from the suction side is pumped over the separator by the turning of the rotor and exhausted outside the pump. This forms a vacuum inside the pump chamber relative to the suction lift, which supports the elasticity of the hose during restoration to its original full cross-section.

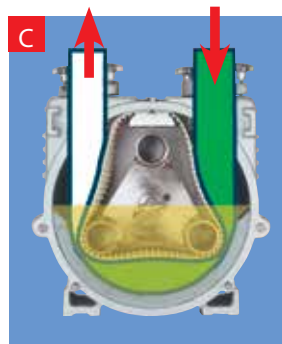

Once the second sliding shoe compresses the hose, a pumping chamber is formed. This volume corresponds exactly to one-third of the pump capacity per rotation. The rotation of the rotor presses the medium inside the hose towards the outlet on the discharge side. During each opening of the hose a vacuum is created on the suction side ensuring constant suction. It also takes place when the hose is empty giving high suction lift conditions.

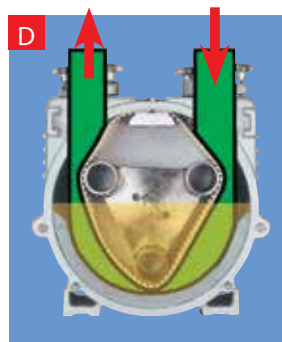

With each rotation the pumping chamber is reformed and the suction capability is renewed.

Coding M300

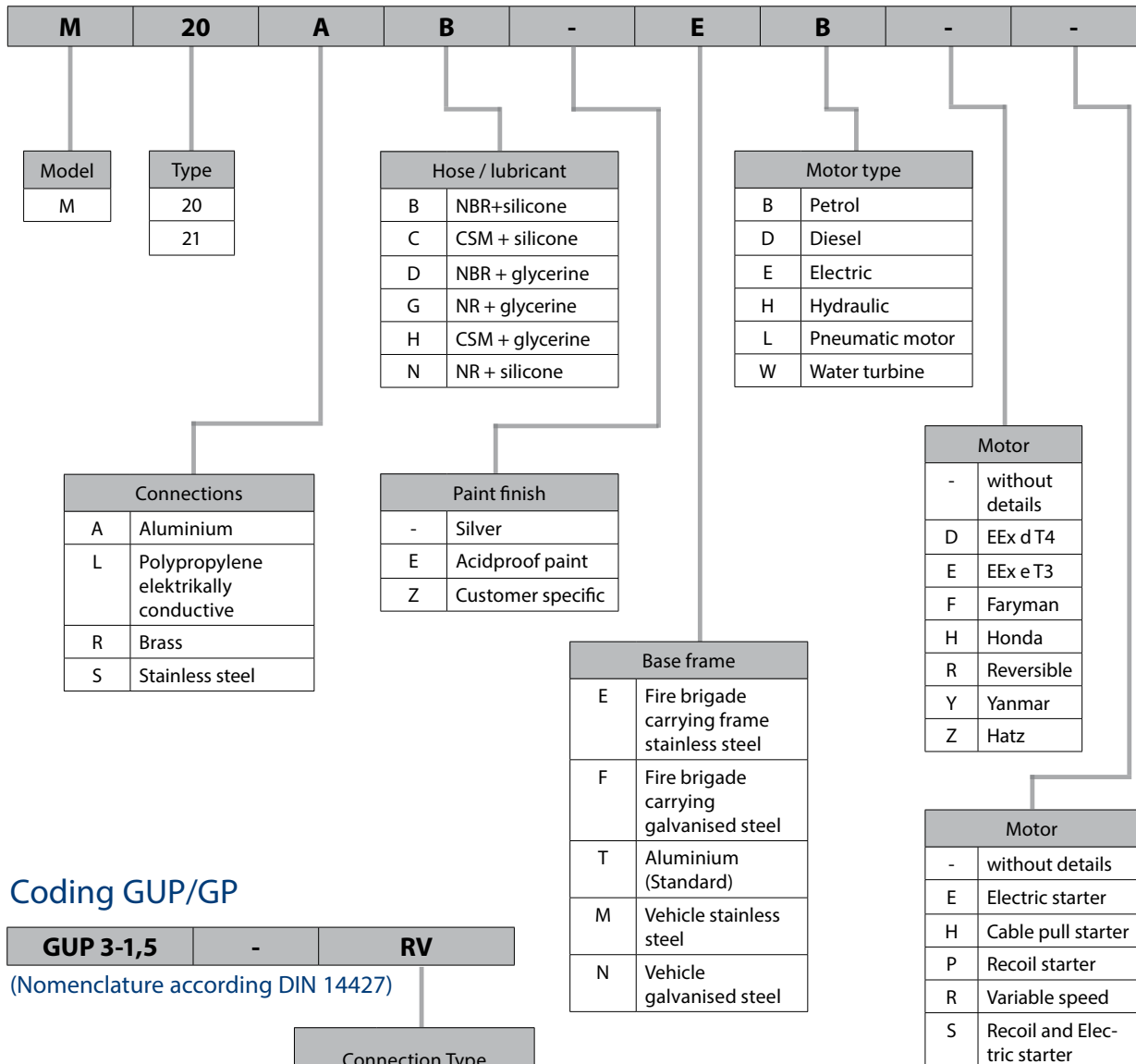

Coding GUP/GP

GUP 3-1,5 **-** **RV**

(Nomenclature according DIN 14427)

Connection Type	
RV	Screw pipe sconnection DIN 11851
TW	Tank truck coupling DIN EN 14420-6

GP 20/10 **EX** **-**

Certification	
ATEX	
Accessories	
-	none
L	light socket

M300 - Dimensions

M300

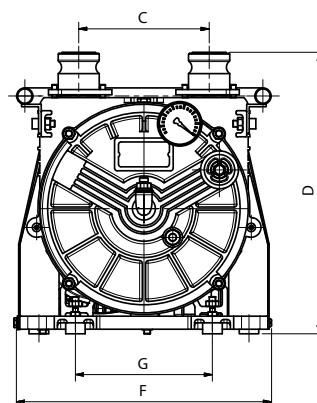
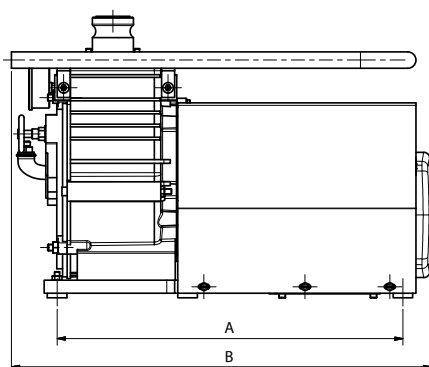
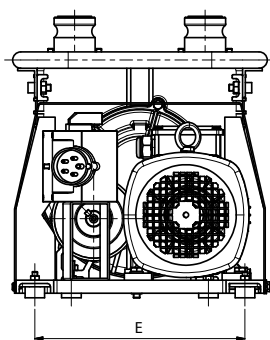

Dimensions (mm)	M20E + reversible	M20B
A	530	530
B	644	628
C	200	200
D	422	432
E	323	323
F	391	390
G	210	210

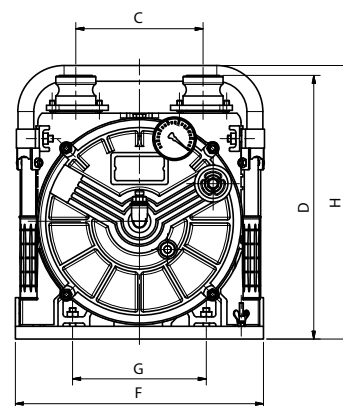
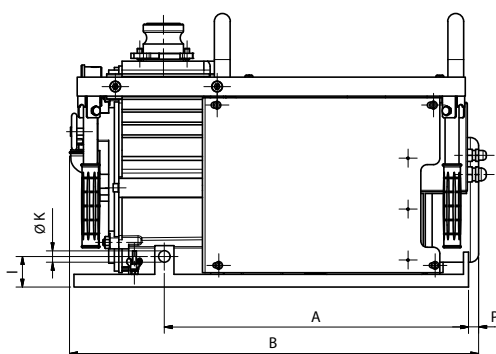
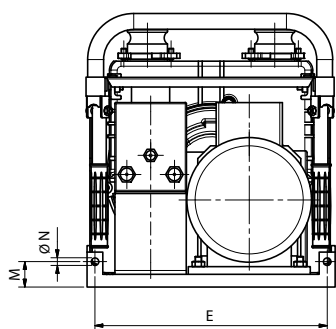

Dimensions (mm)	M20Ex	M20D	M20 H/P/W
A	478	-	478
B	643	665	620
C	200	200	200
D	415	451	415
E	365	-	365
F	390	510	390
G	210	210	210
H	430	507	430
I	48	-	48
K	18	-	18
M	40	-	40
N	12	-	12
P	16	-	-

GUP 3-1,5 & GP20/10 Ex - Dimensions

GUP 3-1,5

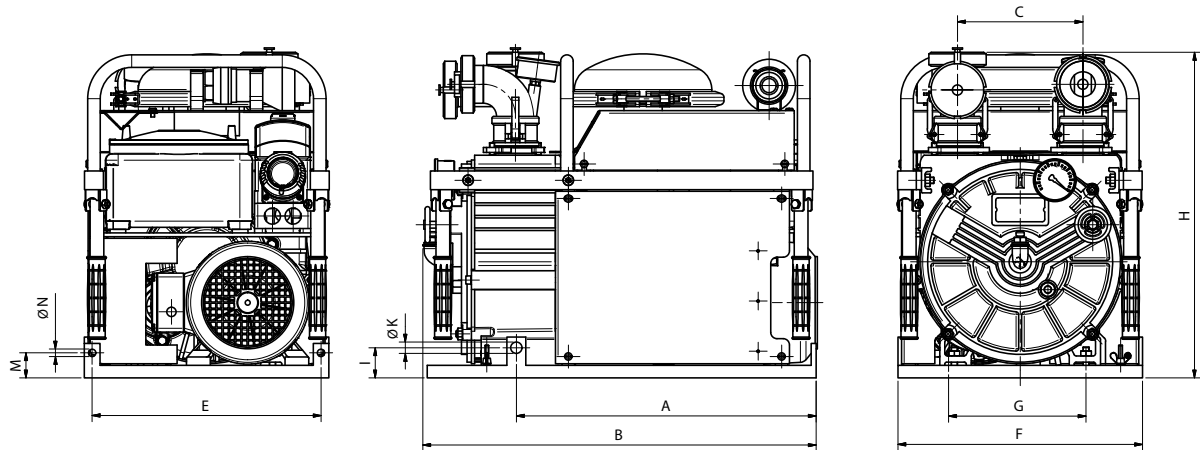

Dimensions (mm)	GUP 3-1,5	GP 20/10 Ex
A	478	478
B	620	620
C	200	200
D	-	415
E	365	365
F	390	390
G	210	210
H	520	515
I	48	48
K	18	18
M	40	40
N	12	12

GP20/10 Ex

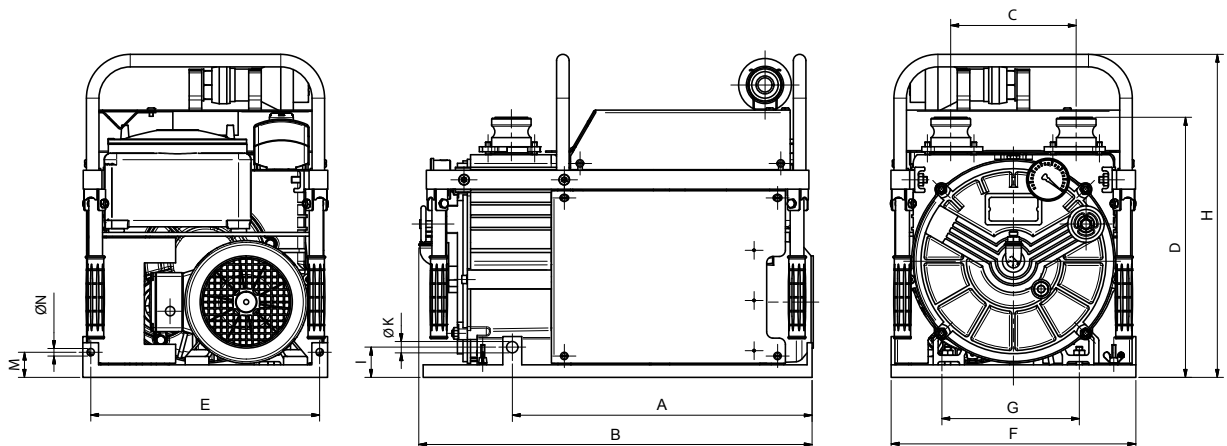

Exploded view M300 and GUP/GP

Exploded View M300

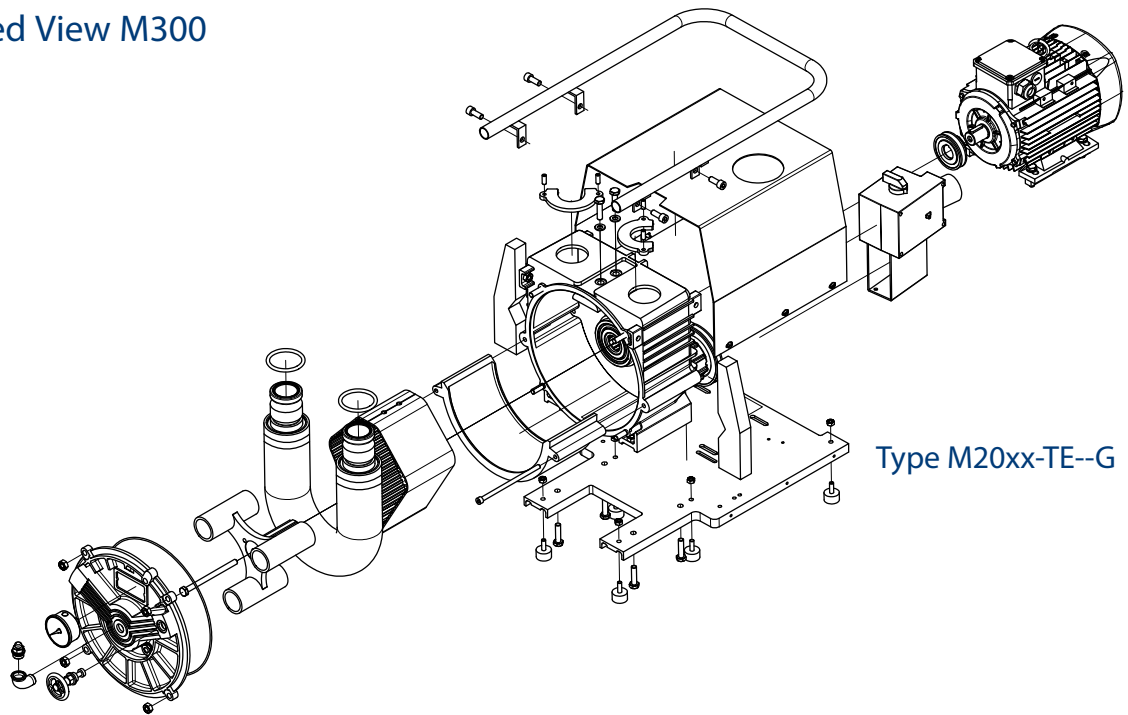

Exploded View GUP/GP

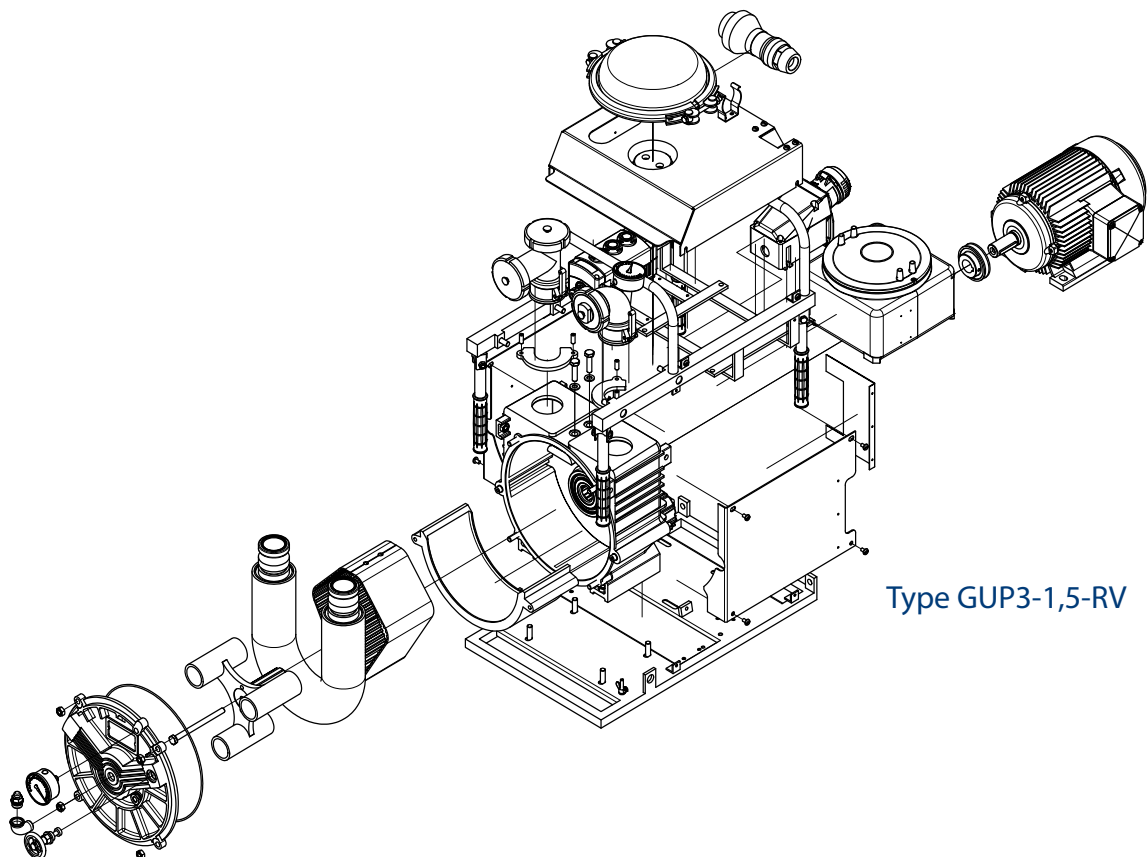

Performance Curves

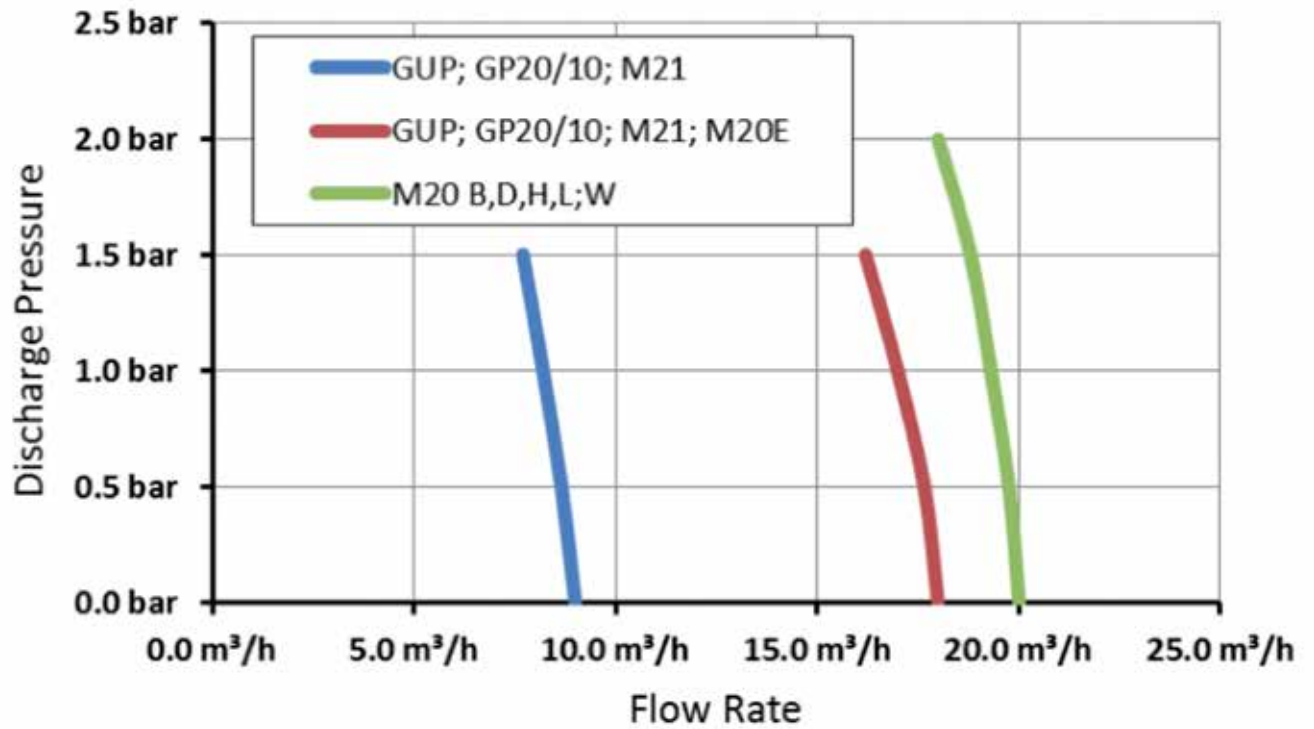

Accessories

ELRO pumps for hazardous material are available with a variety of accessories suitable for any application.

- 1 CL quick release couplings, elbows, Storz couplings and tank vehicle couplings made of stainless steel (only for GP 20/10 Ex)
- 2 Pulsation damper made of stainless steel with T-piece (only for GP 20/10 Ex)
- 3 Suction/discharge hoses are available in the nominal widths of 1" to 4" and are provided with suitable coupling systems completely pressure-tested. Standard spiral hoses with plastic and steel

reinforcement, hoses for chemical applications or suction/discharge hoses approved for food applications.

- 4 180 litre transport drum made of stainless steel with filling equipment
- 5 Hose cleaning device and balls in different designs
- 6 Suction baskets, flat suction nozzle, special suction pipes and residue suction nozzles made of various materials
- 7 Vacuum hose for the ELRO disposal system

Discharge Side Accessories

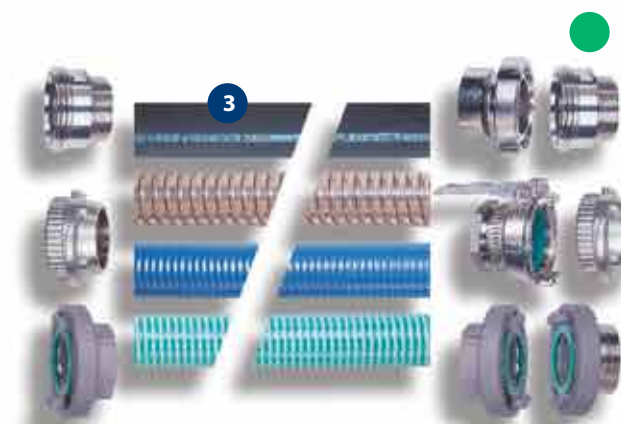

Couplings for hazardous material pump GUP3-1.5, only dairy pipe screw joints DIN 11851

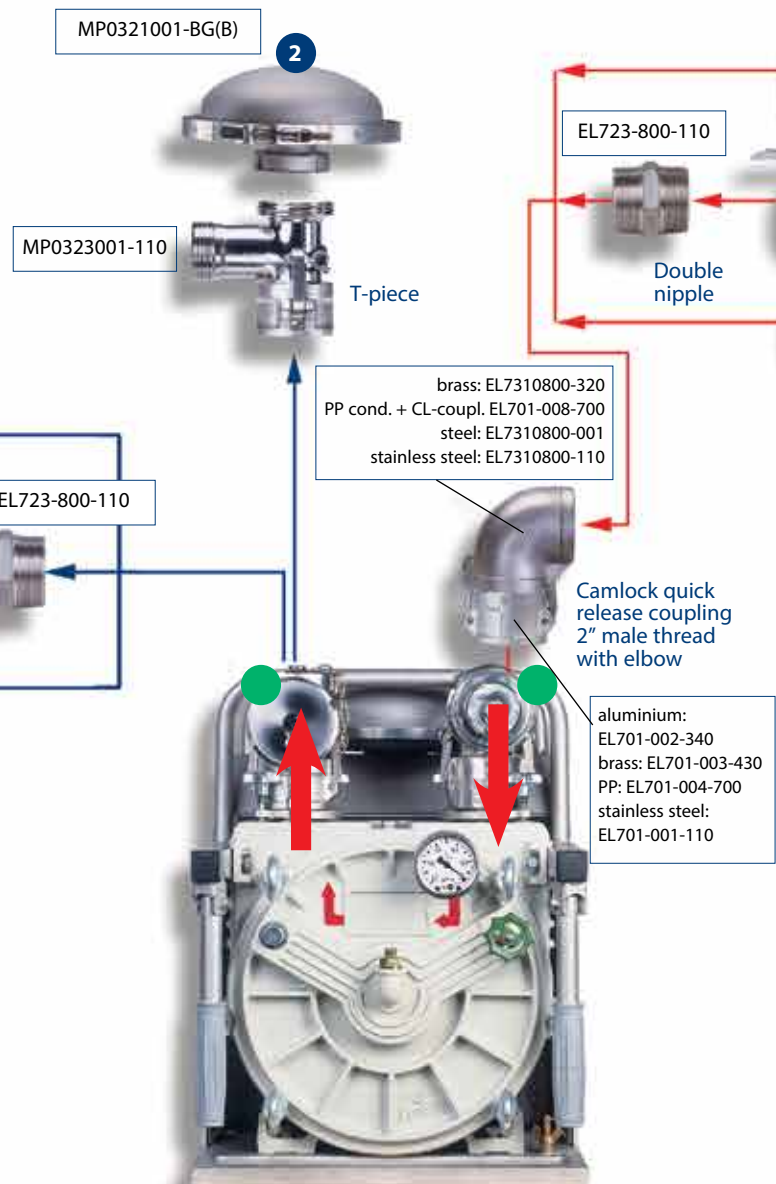

Accessories

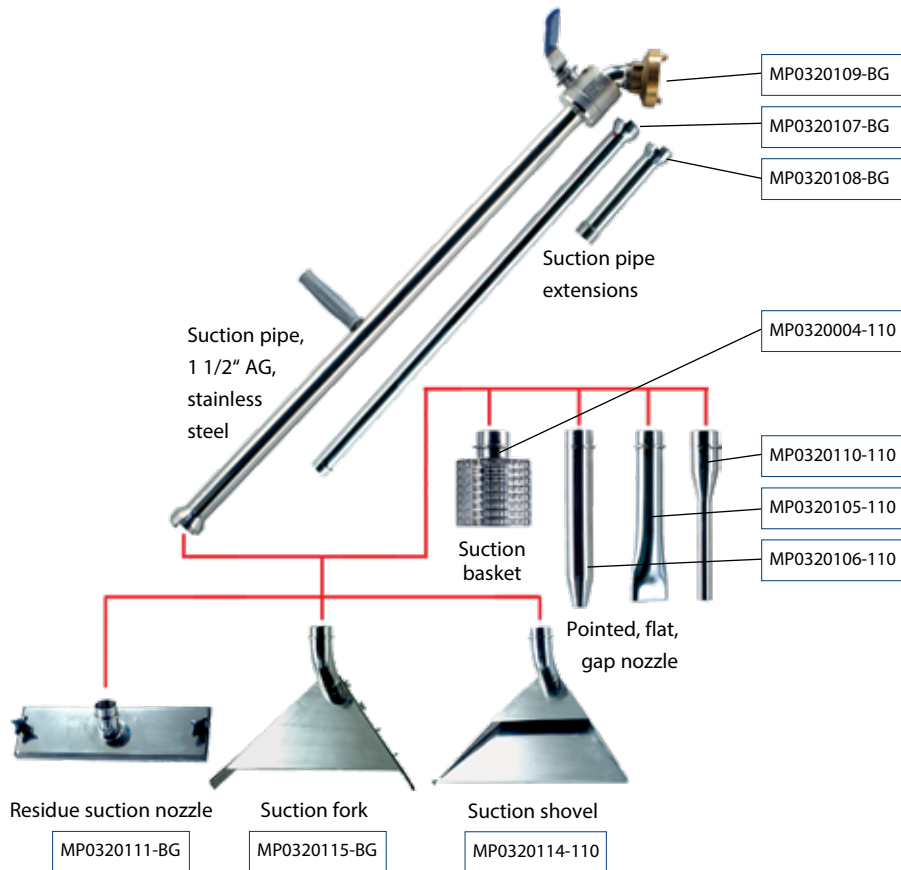

ELRO®

Crane ChemPharma & Energy

Crane Process Flow Technologies GmbH

Heerdter Lohweg 63-71

40549 Düsseldorf, Germany

Tel.: +49 211 5956-0

Fax.: +49 211 5956-111

E-Mail: elro@cranecpe.com

www.cranecpe.com

www.elropumps.com

CRANE®



brands you trust.



CPE-ELRO-GUP-M300-BU-EN-2016_06_17
Edition 06/2016

Die Firma Crane sowie deren Tochtergesellschaften zeichnen sich nicht verantwortlich für mögliche Fehler in Katalogen, Broschüren oder anderen Printmedien sowie der im Internet zugänglichen Informationen. Die Firma Crane behält sich das Recht vor, ihre Produkte ohne gesonderten Hinweis zu ändern. Dies betrifft auch die auf dem Markt befindlichen Produkte, deren Veränderung die Gebrauchstauglichkeit nicht einschränkt, sofern nicht anderweitig festgelegt. Alle Waren und Markenzeichen dieses Materials sind Eigentum der Firma Crane oder deren Tochtergesellschaften. Crane und Crane Markenzeichen (DEPA®, ELRO®, Krombach®, PSI®, Resistoflex®, ResistoPure™, Revo®, Saunders®, WTA®, and XOMOX®) sind eingetragene Warenzeichen der Firma Crane. Sämtliche Rechte an den vorgenannten Warenzeichen sind geistiges Eigentum der Firma Crane oder ihrer Tochtergesellschaften.