

ELRO®

DYSTRYBUTOR
Valmark Sp. z o.o.
tel: (22) 868 58 58
mail: biuro@valmark.pl

brands you trust.



Technical Datasheet
ELRO® Series T
Peristaltic Pumps

CRANE

Crane ChemPharma & Energy

www.elropumps.com
www.cranecpe.com

Features and Benefits

ELRO® Series T peristaltic pumps are characterized by high mobility and outstanding displacement. They have an integrated vacuum system for constant flow rate and a new portable base frame design. A wide range of accessories enables optimal and efficient use in almost every application.

Key Features

- ❶ Mobile unit with flow rates up to 18 m³/h effectively handles a wide range of applications, including contaminated and viscous media
- ❷ The pump is able to self prime up to 9,5mWs without any additional accessories
- ❸ With only one wetted part, the hose, the pump delivers reliable service and with a lower total cost of ownership

Sizes

Type	E-Motor (Electric)	B-Motor (Petrol)	D-Motor (Diesel)
T150	●	-	-
T300	●	●	●

Type	T150E	T300E	T300B	T300D
Dry suction height (m)	max. 9,5*			
Max. solid size (mm)	≤ 12			
Weight (kg)	64	70	59	76

**based on water*



Features and Benefits

Applications

- Environmental technology
- Tank cleaning
- Construction industry
- Plant and tool hire business
- Forwarding agencies
- Docks
- Cleaning companies
- Toilet
- Mobile solutions for trucks

Temperature

Temperature Range: -20°C to +80°C

Product wetted interior	Max. Temperature (°C)
NR	-20 to +80
NBR	-10 to +80
CSM	-20 to +80

Marking and Identification

The pumps are provided with a nameplate containing the pump code, serial number, date of manufacture, and maximum allowed temperature and pressure.

The ELRO® pump code provides all relevant information about the pump, performance, materials and accessories. This allows for accurate linkage to spare parts.

Applied Guidelines

- EC directives: Machinery Directive 2006/42/EC
- Low voltage directive 2006/95/EC
- EMC directive 2004/108/EC
- Harmonized standards: EN ISO 12100, EN ISO 13857, EN 809
- Outdoor directive 2000/14/EC
- RoHS Directive 2011/65/EU



	T150E	T300E	T300B	T300D
Drive	Electric Motor 1.5 kW/ 1400rpm	Electric Motor 3.6 kW/ 2920rpm	Fuel Motor (Gasoline Petrol/Engine) 3.4 kW/ 3600rpm	Diesel Motor (Diesel Engine) 3.5 kW/ 3600rpm
Power Supply	single-phase current 230 V	three-phase current 400V	-	-
Flow rate max.	9m ³ /h	18m ³ /h	18m ³ /h	18m ³ /h
Pumping pressure max.	1.0 bar	1.5 bar	1.5 bar	1.5 bar
Hose Material	CSM, NBR, NR			
Connection Material	Aluminium, Stainless Steel 1.4571, Electrically-conductive Polypropylene, Brass			
ON-Off Switch with Motor protection	x	x	-	-
Protection class	IP54	IP54	-	-
Power connection	2-pole male plug mounted on pump	5-pole male plug with 1,3 m connecting cable	-	-

Pump Coding

T150 E - A B

Drivers	
E	Electric

Connections	
A	Aluminium
L	Electrically-conductive Polypropylene
R	Brass
S	Stainless Steel 1.4571

	Hose	Lubricant
N	NR	Silicone
G	NR	Glycerin
B	NBR	Silicone
D	NBR	Glycerin
C	CSM	Silicone
H	CSM	Glycerin

T300 B - A B

Drivers	
B	Gasoline Petrol Engine
D	Diesel
E	Electric

Connections	
A	Aluminium
L	Electrically-conductive Polypropylene
R	Brass
S	Stainless Steel 1.4571

	Hose	Lubricant
N	NR	Silicone
G	NR	Glycerin
B	NBR	Silicone
D	NBR	Glycerin
C	CSM	Silicone
H	CSM	Glycerin

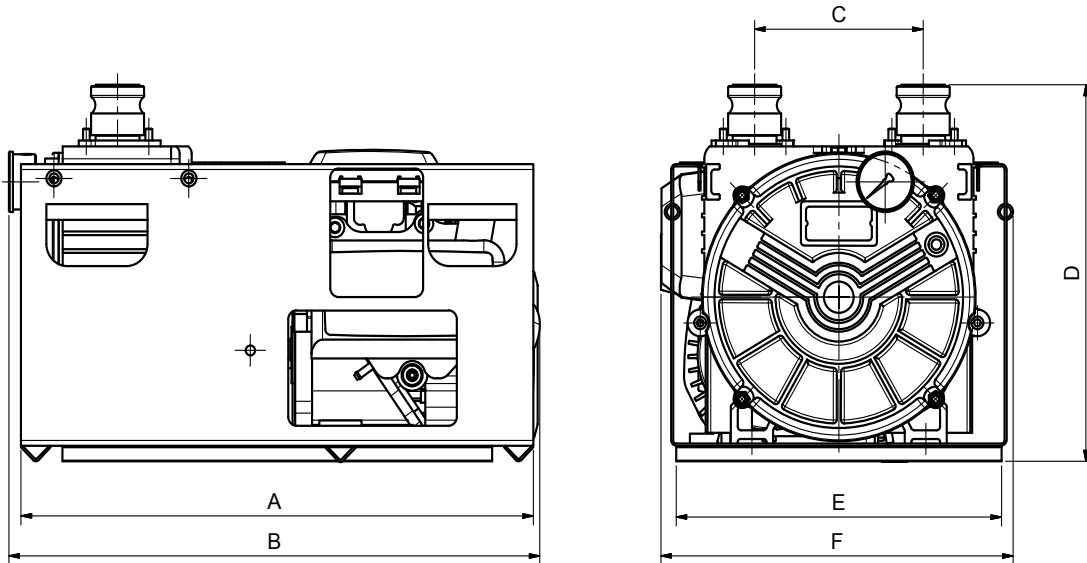

Dimensions (mm)	Type			
	T150E	T300E	T300B	T300D
A	608	608	608	618
B	640	630	630	630
C	200	200	200	200
D	424	424	424	424
E	400	400	400	510
F	415	415	418	525

Exploded view

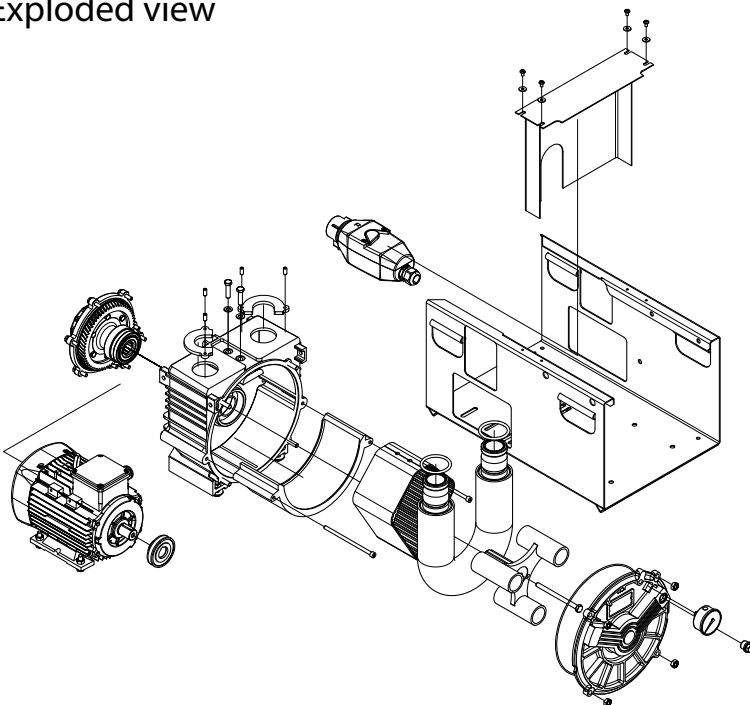

Available Accessories

Connections for CSM, NBR and NR hoses	T150E	T300E	T300B	T300D
Aluminium	X	X	X	X
Stainless Steel 1.4571	X	X	X	X
Polypropylen electrically conductive	X	X	X	X
Brass	X	X	X	X

Elastomers



Natural rubber (NR)

Composition: natural substance, high-polymer isoprenes
 Properties: tension-resistant, elastic, cold-resistant, approved for food applications
 Operative range: for abrasive media, diluted acids and alkalis
 Temperature range: -20°C - +80°C / -4°F - 176°F



Nitrile rubber (NBR)

Composition: compound from butadiene and acryl nitrile
 Properties: wear-resistant, grease and oil resistant
 Operative range: for oily and greasy media, alcohols
 Temperature range: -10°C - +80°C / +14°F - 176°F



Hypalon (CSM)

Composition: elastomer formed through polymerisation of chlorosulfonated ethyls
 Properties : chemical resistant, wear resistant and electric conductive
 Operative range: for acids and alkalis, colours
 Temperature range: -20°C - + 80°C / -4°F - 176°F

ELRO®

Crane ChemPharma & Energy

Crane Process Flow Technologies GmbH

Postfach 11 12 40, D-40512 Düsseldorf

Heerdter Lohweg 63-71, D-40549 Düsseldorf

Tel.: +49 211 5956-0

Fax.: +49 211 5956-111

www.cranecpe.com

www.elropumps.com

CRANE®



brands you trust.



CPE-ELRO-T-ID-EN-A4-MX-2015_02_27
Edition 02/2015

Crane Co., and its subsidiaries cannot accept responsibility for possible errors in catalogues, brochures, other printed materials, and website information. Crane Co. reserves the right to alter its products without notice, including products already on order provided that such alteration can be made without changes being necessary in specifications already agreed. All trademarks in this material are property of the Crane Co. or its subsidiaries. The Crane and Crane brands logotype, in alphabetical order, (ALOYCO®, CENTER LINE®, COMPAC-NOZ®, CRANE®, DEPA®, DUO-CHEK®, ELRO®, FLOWSEAL®, JENKINS®, KROMBACH®, NOZ-CHEK®, PACIFIC VALVES®, RESISTOFLEX®, REVO®, SAUNDERS®, STOCKHAM®, TRIANGLE®, UNI-CHEK®, WTA®, and XOMOX®) are registered trademarks of Crane Co. All rights reserved.